

New Product Launch—FLEXFILL 200

Lingwood are pleased to announce the launch of the new Flexfill 200. This unit has been designed to automatically deposit a pre-determined volume of product into the packaging of your choice. Intended to reduce your reliance on line operatives to control portion size and manually place into the packaging, the Flexfill will reduce your labour costs, product giveaway and improve line efficiency. Thanks to the hygienic design of the unit, product changeovers on the Flexfill 200 can be carried out quickly and easily without the need for skilled personnel. The Flexfill 200 is capable of handling a wide range of products, even those that previously may have been viewed as too delicate or difficult to handle through an automated system.

If you would like to know more about the Flexfill 200, or want to arrange trials with your products, then please contact us at sales@lingwood.net or call 01449 771202

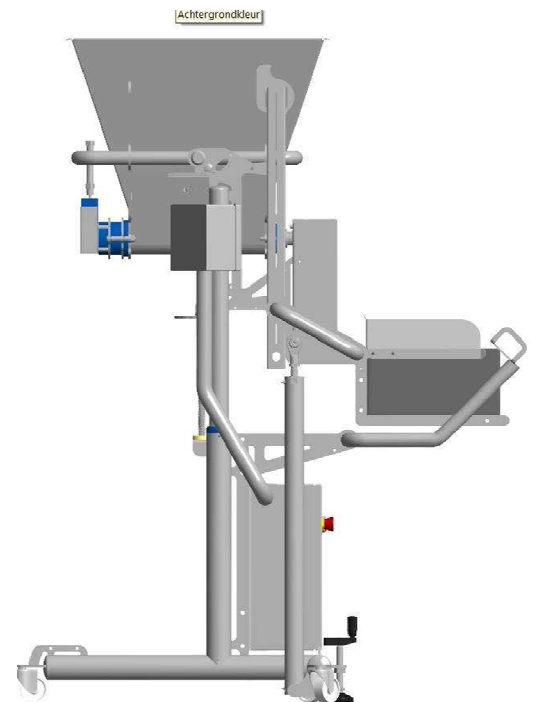
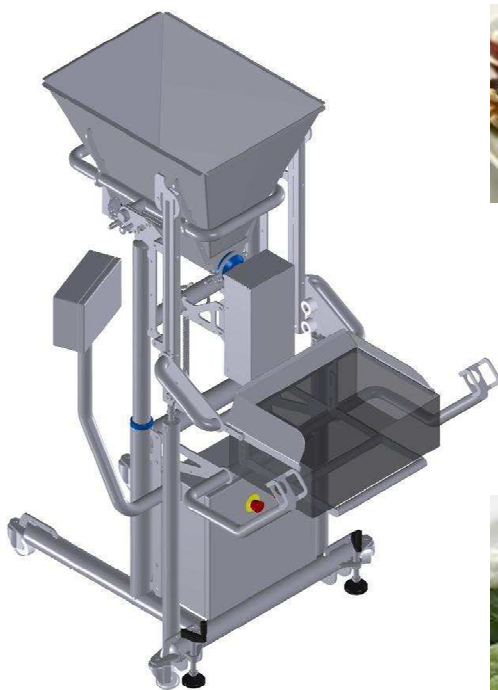

- Provides automatic filling of components into your chosen packaging, therefore, reducing expensive manual filling
- Place “additions” into your salad bowls, vegetable mixes, sandwiches, wraps, fruit salads and more
 - Due to its unique concept, this machine can cope with delicate and difficult to handle products.
 - The filling volume is adjustable by the filling time and speed of the filling head
 - Operating speeds upto 20 cycles per minute dependant upon the type of product and fill volume
 - Option to add a weigh head to increase accuracy and reduce product giveaway
 - The Flexfill 200 stands on a stable frame that can be tilted for easy and safe cleaning access.
 - Infeed hopper volume 100 litres

To arrange a trial - Contact:.....Sales@lingwood.net.....or call 01449 771202