

BOTTOM ROLL TROLLEY

MRS 400



400KG



140-590 mm



304
stainless
steel

- Hygienic innovative design
- Aggressive environments resistant chassis
- Robust and durable structure
- Easy to handle



Watch video

This innovative trolley has been designed and manufactured by ULMA Inoxtruck to make the hard task of replacing the film rolls of the wrapping/packaging machines more ergonomic.

A quick lifting hydraulic system makes bottom roll replacement a quick and ergonomic operation reducing time and high cost

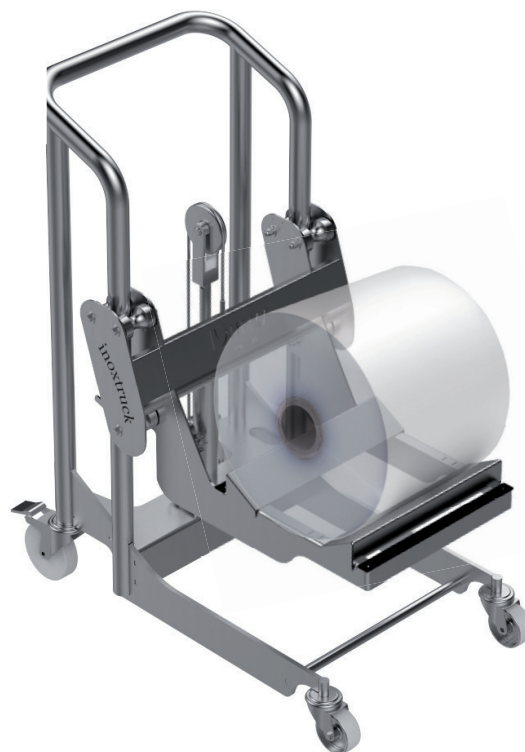

Hygienic Innovative Design

The hygienic design and the rustless materials used make this trolley a life lasting equipment. The only thing to be done to maintain its original appearance and performance is to clean it frequently.



100% Stainless Steel

All the parts including chassis, carriage and hydraulic system have been made in stainless steel AISI 304L (316L optional).

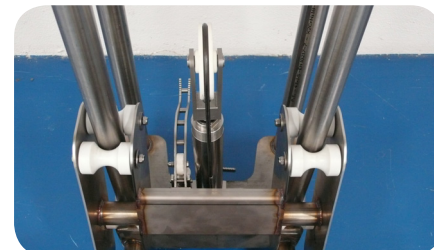

Robust and Easy Handling Trolley

The height and dimensions of the grabbing structure has been ergonomically designed to guarantee optimum driving of the trolley. The drive wheels with brakes make the loading and unloading of the rolls a safe operation.

Front and Side Roll Handling

The lifting carriage has been designed to allow carrying rolls for front or side roll replacement. Two plates with an easy and quick fixing system makes possible to fit rolls with different diameters both width and lengthwise.

Characteristics				
1.1	Manufacturer (Abreviation)			ULMA Inoxtruck
1.2	Manufacturer's model designation			MRS400
1.4	Operator type: manual, pedestrian, operator standing, seated			Manual
1.5	Load capacity	Q	kg	400
1.6	Load center distance	C	mm	400
1.10	Chassis			AISI 304L
1.11	Sheet			AISI 304L
1.12	Truck Weight		kg	45
Roll				
2.11	Diameter (maximum)		mm	600
2.22	Width		mm	720
2.33	Weight		kg	400
Wheels and Drive Train				
3.1	Tyres: P=Polyurethane, PA=Poliamyde (nylon), Vul=Vulko-llan, drive/load side			PA/PA
3.2	Tyre dimensions, drive side			125 X 40
3.3	Tyre dimensions, load side			80 X 30
3.5	Number of wheels, drive/load side (x=driven)			2/2
3.6	Track width (center of tyres), drive side	b10	mm	480
3.7	Track width (center of tyres), load side	b11	mm	480
Dimensions				
4.4	Lift height	h3	mm	450
4.9	Height of handgrip	h14	mm	1100
4.15a	Fork height, fully lowered	h13	mm	135
4.15b	Fork height, fully extended	h12	mm	590
4.19	Overall length	l1	mm	890
4.21	Overall width	b1	mm	585
4.25	Outside width over forks (minimum/maximum)	b5	mm	550
4.32	Ground clearance at center of wheelbase (forks lowered)	m2	mm	50
4.34a	Working aisle width (Ast) load	Ast	mm	1270
4.35	Turning circle radius	Wa	mm	535

ULMA Inoxtruck's products are constantly improving. Because of this reason, some materials, options and specifications can be changed.

OPTIONS:

- Long roll handled on the mandrel.
- Side adjustable stoppers for thin rolls.
- Trolley with spike.
- Ground taxi for JUMBO rolls.

