

firex

friendly innovation



MULTICOOKER

MAJOR LINE

F O O D P R O C E S S I N G E Q U I P M E N T



- **Gb** › BASKET LIFTER
WARNING LIGHT
- It** › SEGNALATORE
LUMINOSO DI
SOLLEVAMENTO CESTI
IN FUNZIONE
- De** › KONTROLLEUCHE
ANHEBEN KÖRBE
EINGESCHALTET
- Fr** › SIGNAL LUMINEUX DE
SOULÈVEMENT DES
PANIER EN MARCHÉ
- Es** › SEÑAL LUMINOSA DE
LEVANTAMIENTO CESTAS
EN FUNCIÓN

- **Gb** › AISI 316 BASKET PERFECT FOR COOKING PASTA,
RICE AND VEGETABLES
- It** › CESTO IN ACCIAIO AISI 316 FORATO ADATTO
ALLA COTTURA DI RISI, PASTA E VERDURE
- De** › GITTERKORB AUS EDELSTAHL AISI 316, GEEIGNET
FÜR DAS KOCHEN VON NUDEL, REIS UND GEMÜSE
- Fr** › PANIER PERCÉ EN AISI 316 ADAPTÉ
À LA CUISSON DE PÂTES, RIZ ET LÉGUMES
- Es** › CESTA PERFORADA EN AISI 316 IDEAL PARA
COCCER PASTA, ARROZ, VERDURAS



- **Gb** › PULL-OUT SHOWER
- It** › DOCCHETTA INTEGRATA
ESTRAIBILE
- De** › HERAUSNEHMBARER
BRAUSEKOPF
- Fr** › DOUCHETTE
EXTRACTIBLE
- Es** › DUCHA EXTRAÍBLE



- **Gb** › LEVEL SENSOR FOR AUTOMATIC
FILLING AND SAFETY CUT-OUT
WHEN VESSEL IS EMPTY
- It** › SONDE DI LIVELLO PER IL
RIPRISTINO AUTOMATICO
DELL'ACQUA IN VASCA
E PER IL BLOCCO DEL
RISCALDAMENTO IN CASO
DI MANCANZA DELLA STESSA
- De** › FÜLLSTANDSSONDE FÜR DAS
AUTOMATISCHE NACHFÜLLEN
VOM WASSER IM BECKEN UND
FÜR DAS ABSCHALTEN DER
HEIZUNG BEI WASSERMANGEL
- Fr** › SONDES DE NIVEAU POUR LE
REMPLEISSAGE AUTOMATIQUE
DE L'EAU DANS LA CUVE ET
POUR LE BLOCCAGE DU
RÉCHAUFFEMENT EN CAS
DE MANQUE D'EAU
- Es** › SONDA DE NIVEL PARA
EL LLENADO AUTOMÁTICO
DEL AGUA EN LA CUBA Y PARA
BLOQUEAR EL CALENTAMIENTO
EN CASO DE QUE FALTE EL AGUA



- **Gb** › STARCH OVERFLOW AND
SKIMMING TAP
- It** › RUBINETTO PER LO
SFIORAMENTO E SCARICO
DEGLI AMIDI
- De** › ÜBERLAUFHAHN UND HAHN
ZUM ABLASSEN VON STÄRKE
- Fr** › ROBINET ANTI-DÉBORDEMENT
ET VIDANGE DES AMIDES
- Es** › GRIFO PARA LA DESCARGA DE
LOS LÍQUIDOS EN EXCESO Y
DE LOS ALMIDONES

**AUTOMATIC COOKERS
CUOCITORI AUTOMATICI
AUTOMATISCHE KOCHGERÄTE
CUISEURS AUTOMATIQUES
COCEDORES AUTOMÁTICOS**



■ **Gb** › This range - developed for the specific needs of catering - includes 21 different models with 1 or 2 pans and independent baskets. Flexible cooking equipment that can carry out most of the traditional cooking in water, such as those regarding any type of pasta, rice, soup, white and red meat, vegetables, etc. The technology used for the production of these machines guarantees fast and safe operating cycles, constant product quality, utmost working reliability and a better use of human resources.

■ **It** › Questa gamma, nata per specifiche necessità della grande ristorazione, si compone di ben 21 modelli ad una o due vasche con cestelli indipendenti. La flessibilità di queste macchine fa sì che nelle

stesse possano essere effettuate gran parte delle tradizionali cotture in acqua, come quelle relative ad ogni tipo di pasta, riso, minestre, carni bianche e rosse, verdure, ecc. Le tecnologie usate nella costruzione delle macchine garantiscono velocità e sicurezza dei cicli di lavoro, qualità costante del prodotto, alta affidabilità di esercizio e miglior impiego delle risorse umane.

■ **De** › Dieses Geräteprogramm, das für die spezifischen Anforderungen aller Einsatzbereiche der Großküche und der Gemeinschaftsverpflegung entwickelt worden ist, besteht aus 21 verschiedene Ausführungen, ausgerüstet mit 1, 2 Kochbehälter und unabhängige Kochkörbe. Dank der Flexibilität dieser Geräte, kann man die meisten herkömmlichen

Kochzubereitungen wie Teigwaren, Reis, Suppen, Kochfleisch, Gemüse u.s.w. problemlos durchführen. Die in der Fertigung der Geräten angewendeten innovativen Technologien gewährleisten schnelle und sichere Arbeitsvorgänge, konstante Qualität des Personals.

■ **Fr** › Cette gamme, créée pour des exigences spécifiques de la grande restauration, est composée de 21 modèles à une cuve ou deux cuves avec paniers indépendants. Ces appareillages-çi, grâce à leurs flexibilités, permettent d'effectuer grande partie des cuissons traditionnelles à eau, indiquée pour pâtes, riz, potages, viandes blanches et rouges, légumes, etc. L'emploi de technologie avancée assure vitesse et sécurité des cycles de travail, qualité constante

du produit, haute fiabilité d'exercice et meilleur emploi des ressources humaines.

■ **Es** › Esta gama, creada para necesidad específicas del sector de la gran restauración, se compone de 21 modelos con 1 o 2 cubas y cestos independientes. La flexibilidad de estas máquinas las hace adecuadas ya sea para la mayoría de las cocciones tradicionales en agua como para la cocción de cualquier tipo de pasta, arroz, sopas, carnes blancas y rojas, verduras, etc. Las tecnologías utilizadas en la construcción de las máquinas garantizan velocidad y seguridad de los ciclos de trabajo, calidad constante del producto, alta confiabilidad de funcionamiento y un empleo más racional de los recursos humanos.



ALCUNE APPLICAZIONI DI MULTICOOKER

MOST SUCCESSFUL PRODUCTS OF MULTICOOKER



- Brodi
- Riso
- Pasta
- Pesce
- Carne
- Uova
- Verdure
- Legumi
- Stock
- Rice
- Pasta
- Fish
- Meat
- Eggs (clodding eggs too)
- Vegetables
- Legumes

CARATTERISTICHE COSTRUTTIVE

- Struttura portante in AISI 304 con spessore 30/10.
- Rivestimenti esterni in AISI 304.
- Vasca in acciaio inox AISI 316 dello spessore di 30/10.
- Cestelli forati in acciaio inox AISI 316.
- Rubinetto di scarico frontale in ottone cromato da 2" dotato di maniglia isolante.
- Coperchio bilanciato realizzato in acciaio inox AISI 304.
- Carico e reintegro automatico dell'acqua all'interno della vasca.
- Troppopieno e rubinetto per lo sfioramento degli amidi.
- Doccia estraibile per il raffreddamento rapido del prodotto e per facilitare le operazioni di lavaggio della vasca.
- Cestelli elevabili e ribaltabili



automaticamente con sosta nella posizione di sgocciolamento.

- Sistema di controllo che garantisce il blocco riscaldamento in mancanza d'acqua.

RISCALDAMENTO:

- **Versioni a gas:**
per mezzo di bruciatori tubolari ad alto rendimento, sistema automatico di accensione e sorveglianza di fiamma, senza bruciatore pilota.
- **Versioni elettriche:**
riscaldamento diretto per mezzo di resistenze corazzate in lega "Incoloy 700".

• Versione vapore:

- regolazione del vapore tramite valvola parzializzatrice per l'immissione graduale del vapore;
- intercapedine in acciaio inox AISI 304;
- pressione massima 0,5 bar;
- gruppo di controllo e sicurezza costituito da valvola di depressione, manometro di controllo e valvola di sicurezza.

CONSTRUCTIVE FEATURES

- *Stainless steel AISI 304 carrying structure.*
- *Exterior cladding AISI 304 stainless steel.*
- *AISI 316 stainless steel pans, 3 mm thick.*
- *Perforated baskets made of AISI 316 stainless steel.*
- *Front drain tap made of 2" chrome-plated brass with insulating handle.*
- *Counterbalanced lid in AISI 304 stainless steel.*
- *Automatic filling and reinstating of water inside the pan.*
- *Overflow device and starch skimming tap.*
- *Extractable shower head to cool food rapidly and wash the pan.*
- *Baskets lifting and tilting automatically with standstill in dripping position.*
- *Control system to assure that the machine stops if without water.*

HEATED:

- **Gas versions:**
are heated via high capacity



stainless steel tubular pilotless burners, with automatic ignition and flame control device.

• Electric versions:

by means of armoured "Incoloy 700" elements.

• Steam versions:

- *heated by steam, introduced into the jacket from an external mains supply and fitted with a control valve which provides infinite variable heat input.*
- *Steam is controlled by a pressure switch, safety valve and pressure gauge, thermostatic valve.*
- *Jacket walls made of AISI 304 stainless steel.*
- *Maximum pressure 0,5 bar.*





SEMPLICITÀ ELETTRONICA

Caratteristiche della scheda Firex:

- è estremamente facile da comprendere e da utilizzare
- garantisce di impostare temperature estremamente precise con valori da 20°C fino a 110°C
- permette di impostare il tempo di cottura inteso come tempo di immersione del cesto con intervallo minimo di 30 secondi
- controlla i movimenti del cesto
- garantisce il riempimento automatico della vasca e il mantenimento del livello necessario per la continuazione della cottura in cicli consecutivi
- blocca il riscaldamento in caso di livello di acqua insufficiente
- lega al sollevamento del cesto il segnale del lampeggiatore luminoso arancione
- standard prevede regolazione acqua calda o fredda per la doccetta estraibile per il raffreddamento

- del prodotto o per la pulizia
- è sempre predisposta per il collegamento al pc e al controllo HACCP
- fornisce semplici messaggi e allarmi per identificare e correggere i più comuni errori di utilizzo
- dispone di due display digitali a 3 cifre che mostrano temperatura impostata e temperatura prodotto o tempo mancante alla fine del ciclo di cottura
- indica con un segnale luminoso costante se il riscaldamento è attivo.

ELECTRONIC SIMPLICITY

Firex electronic card features:

- is extremely easy to learn and to use
- allows to set temperatures very precise with values from 20°C to 110°C
- gives the possibility to set the cooking time, in the meaning

- of basket immersion, with minimum value of 30 seconds
- controls the basket movements
- grants the automatic filling of the vessel and the maintaining of the necessary level of water for continuous cycles of cooking
- stops the heating in case of not sufficient water level
- connects the basket surfacing with the orange lamp signal
- standard permits water regulation hot/cold for the shower for product cooling down or for cleaning.
- is standarly prepared to be connected with the PC for the HACCP control
- provides simple messages and alarms to help to identify and correct the most commun errors of use
- has 2 digital displays with 3 digits showing product and set temperature or countdown for end of cooking time
- shows with a continous light signal that heating is on.

PRINCIPALI ACCESSORI E OPTIONAL

- Rubinetto di scarico in acciaio
- HACCP Controller
- Vasca di raffreddamento
- Carelli

MAIN OPTIONALS AND ACCESSORIES

- Washout stainless steel
- HACCP Controller
- Cooling basin trolley, upon request
- Trolleys



INSTALLAZIONE / INSTALLATION

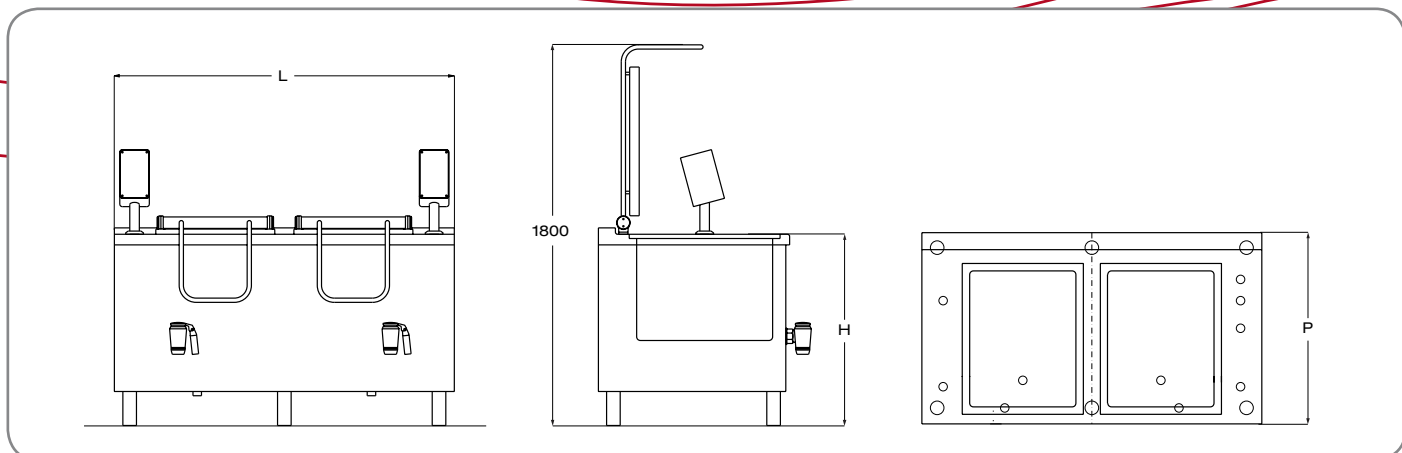

CUOCITORI AUTOMATICI / AUTOMATIC COOKERS

Modello Model	Dimensioni Dimensions mm (L x P x H)	Vasca di cottura * Cooking Vessel			Versione Gas Gas Version		Versione vapore Steam Version		Versione Elettrica Electric Version	
		Vasca Vessel nr.	Capacità vasca Vessel capacity lt.	Capacità cesto Basket capacity kg.	Potenza gas Gas power rating Kw	Collegamento elettrico Elect. connection V/Hz	Consumo vapore Steam consumption Kg/h	Collegamento elettrico Elect. connection V/Hz	Collegamento elettrico Elect. connection V/Hz	Potenza elettrica Elect. power rating Kw
1-12	800x900 h. 900	1	135	12/15	27	230/50 AC - 1N + PE	15	230/50 AC - 1N + PE	400/50 3N+PE AC	16,5
1-18	1000x900 h. 900	1	188	18/23	36	230/50 AC - 1N + PE	45	230/50 AC - 1N + PE	400/50 3N+PE AC	22
1-24	1200x900 h. 900	1	242	24/30	45	230/50 AC - 1N + PE	60	230/50 AC - 1N + PE	400/50 3N+PE AC	27,5
1-10/10	1400x900 h. 900	1	242	2x10/13	45	230/50 AC - 1N + PE	60	230/50 AC - 1N + PE	400/50 3N+PE AC	27,5
2-12	1600x900 h. 900	2	2x135	2x12/15	27+27	230/50 AC - 1N + PE	35+35	230/50 AC - 1N + PE	400/50 3N+PE AC	16,5+16,5
2-18	2000x900 h. 900	2	2x188	2x18/23	22+22	230/50 AC - 1N + PE	45+45	230/50 AC - 1N + PE	400/50 3N+PE AC	22+22
2-24	2400x900 h. 900	2	2x242	2x24/30	27,5+27,5	230/50 AC - 1N + PE	60+60	230/50 AC - 1N + PE	400/50 3N+PE AC	27,5+27,5

* Pasta secca KGS / Dry pasta KGS

VERSIONI / VERSIONS



CPMIV1-12
VERSIONE VAPORE
STEAM HEATED



CPMDE1-24
VERSIONE ELETTRICA
ELECTRIC HEATED



CMPDG2-12
VERSIONE GAS
GAS HEATED



f i r e x . i t

firex[®]
friendly innovation

COMPANY
WITH QUALITY MANAGEMENT
SYSTEM CERTIFIED BY DNV
=ISO 9001:2008=

COMPANY WITH
SAFETY SYSTEM
CERTIFIED BY DNV
=OHSAS 18001=



I dati riportati sono indicativi. L'Azienda si riserva di apportare in qualsiasi momento variazioni senza preavviso. / The information herein is indicative and not binding. The company reserves the right to make alterations at any time without notice. / Die vorliegenden Daten sind nicht bindend. Die Firma behält sich vor, jederzeit ohne Vorankündigung Änderungen vorzunehmen. / Les données reportées sont fournies à titre indicatif. Notre firme se réserve le droit d'effectuer des variations à tout moment sans préavis. / Los datos descritos son indicativos. El fabricante se reserva de aportar variaciones en cualquier momento sin previo aviso.

© 2011 - graphics by alitadada.it - printed in Italy by grafiche italprint